



# ARİŞ ENERJİ INC. COMPANY & PRODUCTS OVERVIEW



NOVEMBER 2024



# ABOUT COMPANY

- Foundation: 1987
- Engineering & Contracting Company
- Location: Ostim Technopolis Area, Ankara, TR



ARIS  
ENERJİ



# ABOUT COMPANY

➤ Personnel: 29

➤ White Collar: 11 (7 Engineers)

➤ Blue Collar: 18

➤ Partners

Burak YILDIZ (Electrical Engineer)

Zeynel Fatih TAŞ (Mechanical Engineer)





# ABOUT COMPANY - ACTIVITY AREAS

- Biogas to Power & Natural Gas
- LandFillGas (LFG) to Power & Natural Gas
- Tailor made solutions
- Plant Operation







# ACTIVITIES— BIOGAS PROJECTS

Biogas – Anaerobic Digestion Projects:

- Biogas Power Plant Equipment Design & Manufacturing
- Piping & Equipment Installation
- Automation & Cabling
- Basic&detail Design for Power Plant





# ACTIVITIES— LFG PROJECTS

(MSW – Municipal Solid Waste)

- LandFillGas (LFG) Power Plant Plant Equipment Design & Manufacturing
- LFG – Project Development, Site Piping, Plant Design, Automation
- LandFillGas (LFG) Power Plant Operation







# ABOUT COMPANY - ACTIVITY AREAS

- Non-Standard (Tailor Made) Equipment Design & Production (according to customer requirements)





# ABOUT COMPANY - PRODUCTS



Booster System

Gas Cooler

Gas Flare

Desulphurisation System

Siloxane Removal System

Gas Holder

Waste Heat Exchanger

Air Cooled Gas Cooler

Double Pipe Exchanger

Hygenesation System

Cyclone Seperator

Actived Carbon Filter

Silencer, Jet Cap, 3 Way Valve

Gas Scrubber





# ABOUT COMPANY - PRODUCTS

## BOOSTER SYSTEM

Booster System includes Blowers, Gas analyser and other instruments to pressurization, analyse, filtering (simply) the gas.

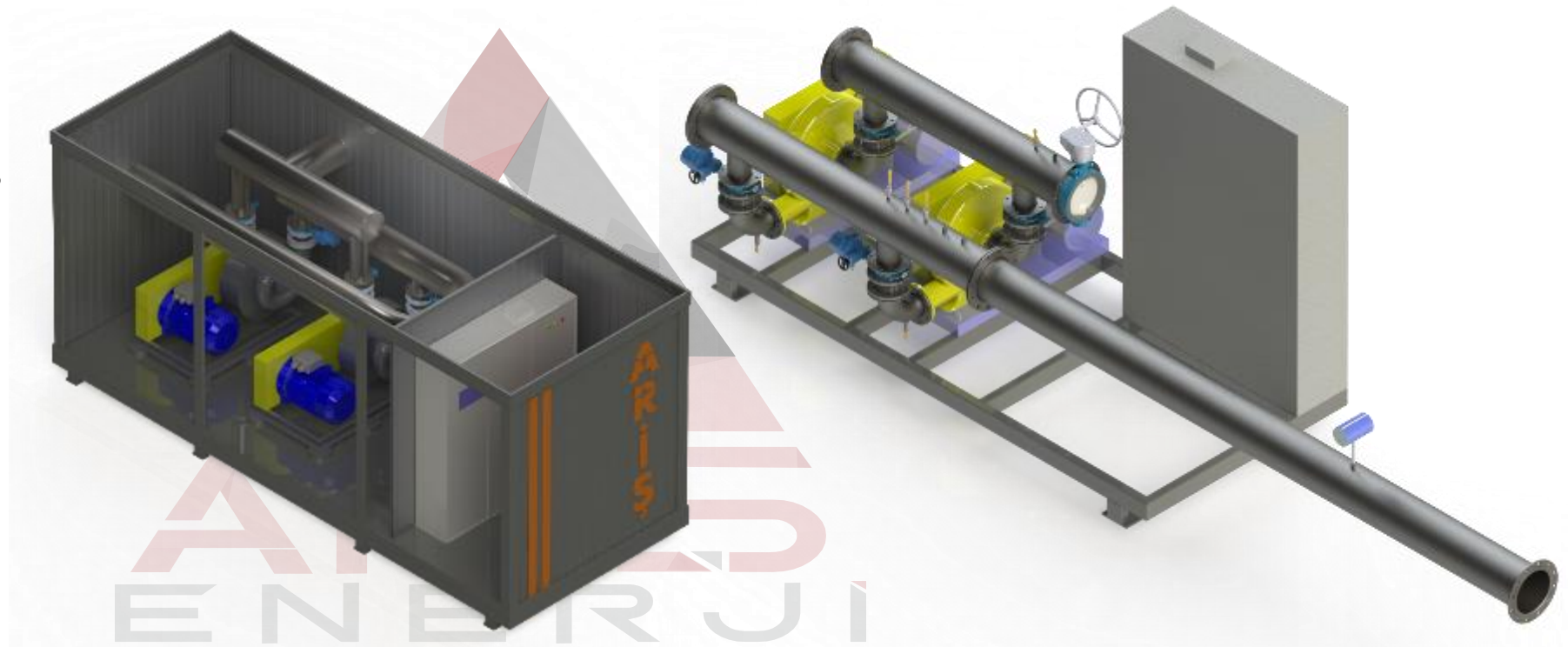



# ABOUT COMPANY - PRODUCTS

BOOSTER SYSTEM





# ABOUT COMPANY - PRODUCTS

## GAS FLARE – ELEVATED

Emergency Gas Flares from  
100 m<sup>3</sup>/h to 1.000 m<sup>3</sup>/h







# ABOUT COMPANY - PRODUCTS

GAS FLARE – ELEVATED





# ABOUT COMPANY - PRODUCTS

GAS FLARE – GROUND

Emergency Gas Flare

200 m<sup>3</sup>/h to 5.000 m<sup>3</sup>/h

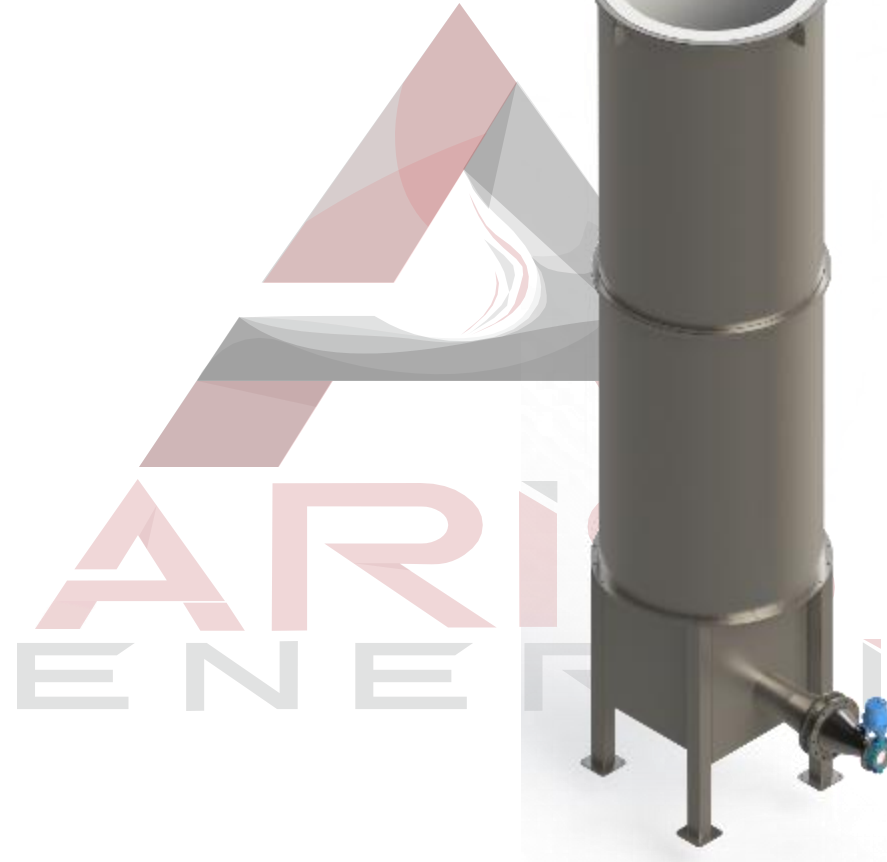





# ABOUT COMPANY - PRODUCTS

## GAS FLARE - GROUND







# ABOUT COMPANY - PRODUCTS

GAS COOLER – WATER COOLED

Gas cooling down to 0 °C

From 100 m<sup>3</sup>/h to 5.000 m<sup>3</sup>/h





# ABOUT COMPANY - PRODUCTS

GAS COOLER – WATER COOLED





# ABOUT COMPANY - PRODUCTS

## GAS COOLER – AIR COOLED

Uses ambient air temperature to cool the gas.

This is the first step of Cooling for high temperature gases to decrease Power Consumption.







# ABOUT COMPANY - PRODUCTS

GAS COOLER – AIR COOLED





# ABOUT COMPANY - PRODUCTS

## GAS HOLDER

Double Membrane Gas Holder

400 m<sup>3</sup> – 16.000 m<sup>3</sup> Gas Storage

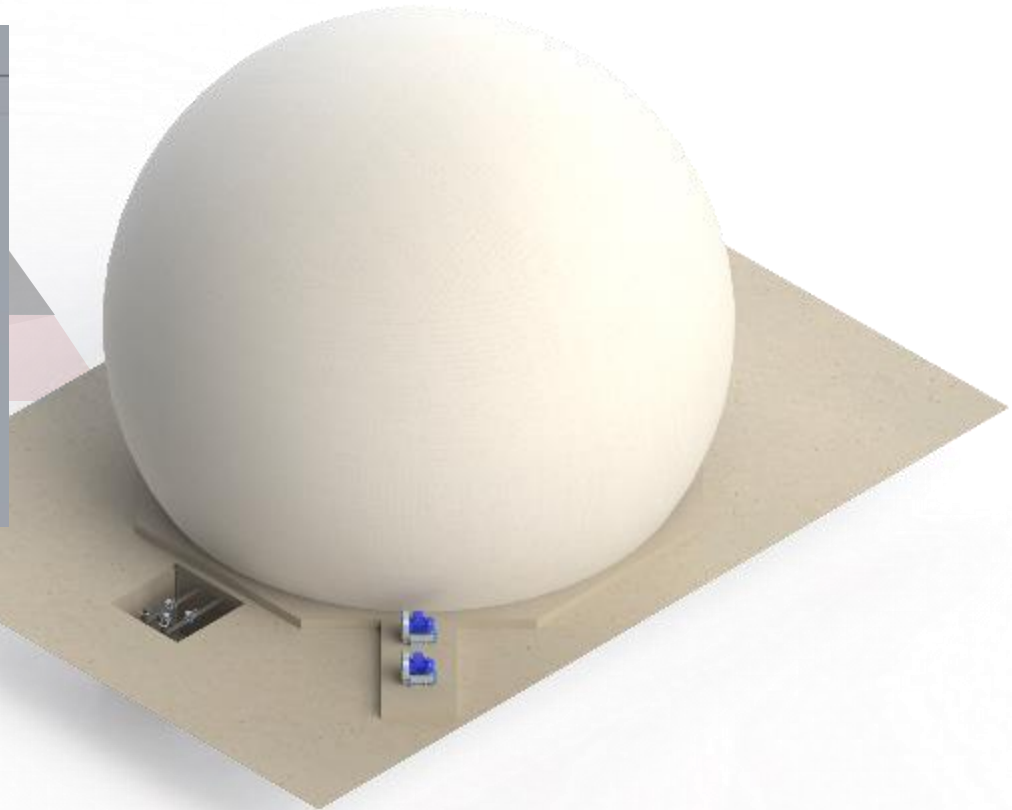
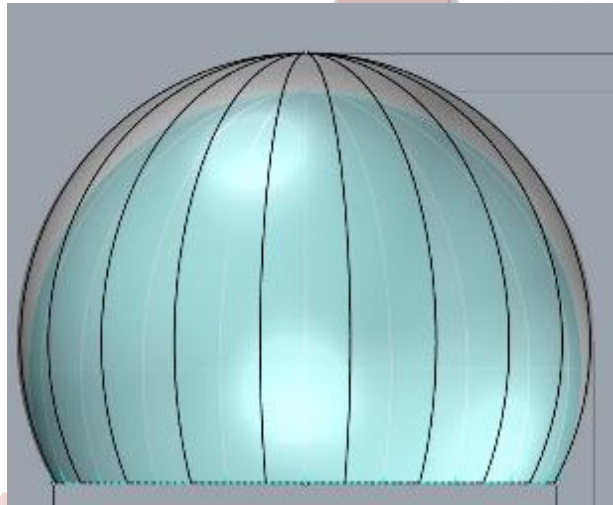

ENERJI



# ABOUT COMPANY - PRODUCTS

## GAS HOLDER







# ABOUT COMPANY - PRODUCTS

## ACTIVED CARBON FILTER

Stainless-Steel filters for  
dry desulphurisation

Special design for multiple  
Filters required

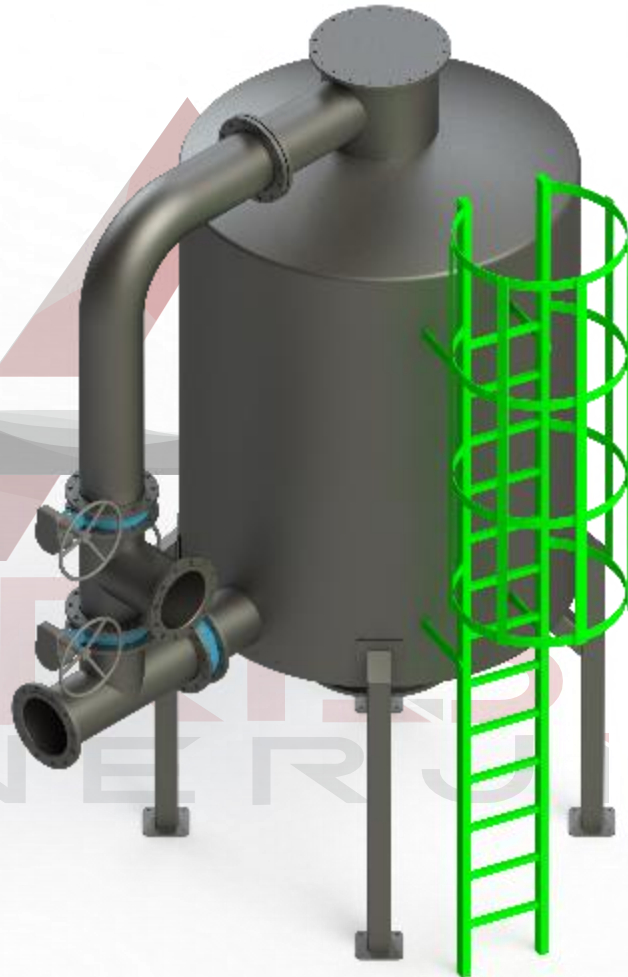



# ABOUT COMPANY - PRODUCTS

ACTIVED CARBON FILTER





# ABOUT COMPANY - PRODUCTS

## DOUBLE PIPE HEAT EXCHANGER

Used to heat up the feedstock for digester or pasteurisation systems.

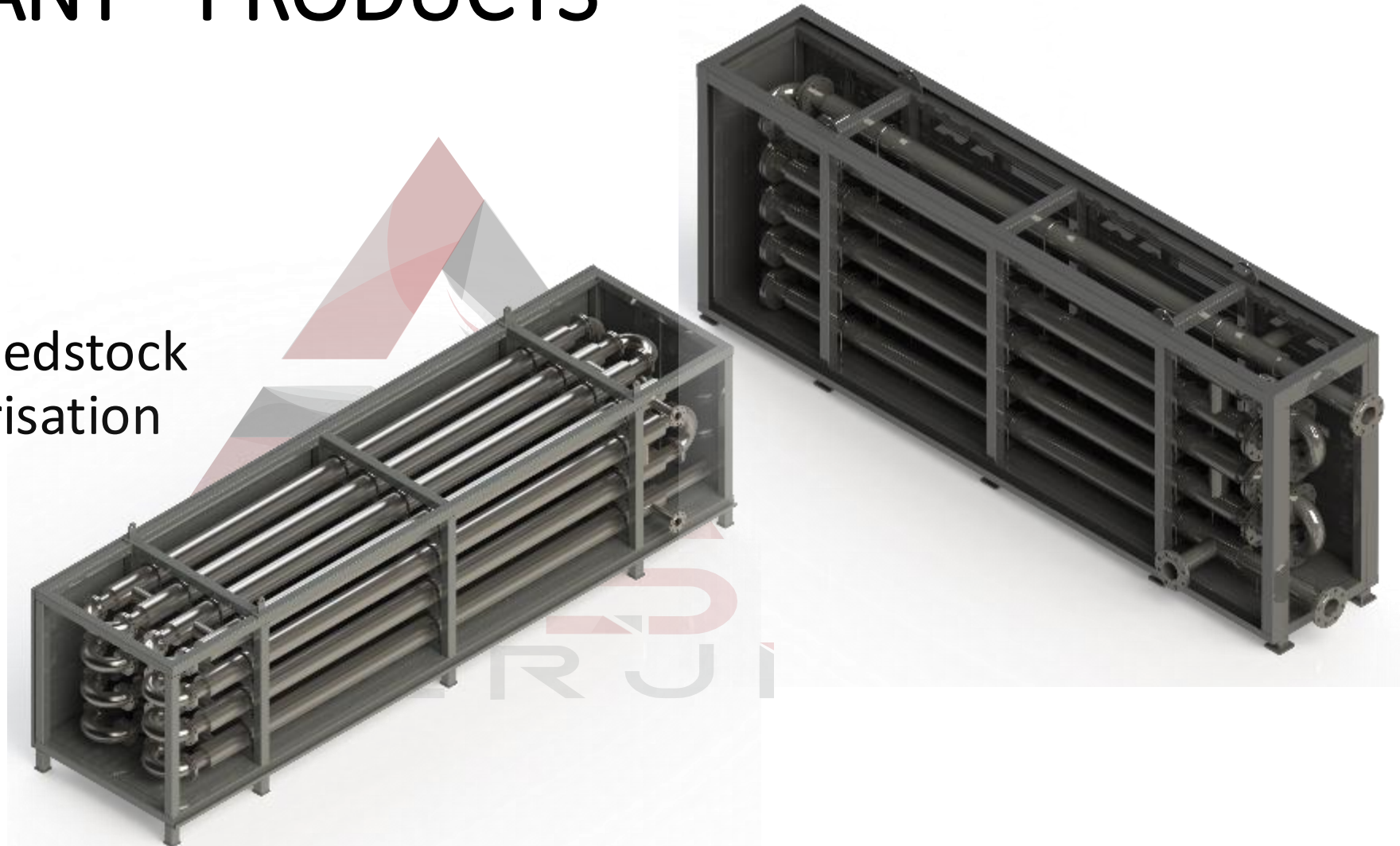





# ABOUT COMPANY - PRODUCTS

## DOUBLE PIPE HEAT EXCHANGER





# ABOUT COMPANY - PRODUCTS

## PASTEURISATION SYSTEM (HYGENISATION SYSTEM)

Used to pasteurize the digestate at 70°C for 1 hour.

Either with one or two tanks depending on process and requirements.







# ABOUT COMPANY - PRODUCTS

## PASTEURISATION SYSTEM







# ABOUT COMPANY - PRODUCTS

## WASTE HEAT RECOVERY HEAT EXCHANGERS

Uses waste heat as a heat source.





# ABOUT COMPANY - PRODUCTS

## HEAT EXCHANGERS



Heat Exchanger

[www.arisenerji.com](http://www.arisenerji.com)



# ABOUT COMPANY - PRODUCTS

## GRAVEL FILTER

Used to filter sediments or other particles in gas.

It can be in scope of Booster System.







# ABOUT COMPANY - PRODUCTS

## GRAVEL FILTER





# ABOUT COMPANY - PRODUCTS

## CONDENSATE SEPERATOR

Used to remove condensate from gas streams by utilizing centrifugal force.

It can be in scope of Gas Cooler.





# ABOUT COMPANY - PRODUCTS

## CONDENSATE SEPERATOR







# ABOUT COMPANY - PRODUCTS

## FLAME ARRASTER

A safety equipment that is used to prevent flame penetration to gas.

Generally used in lines to Flare.





# ABOUT COMPANY - PRODUCTS

## FLAME ARRASTER





# ABOUT COMPANY - PRODUCTS

## CHP UNIT

CHP container design and manufacturing, cabling & piping according to requirements.

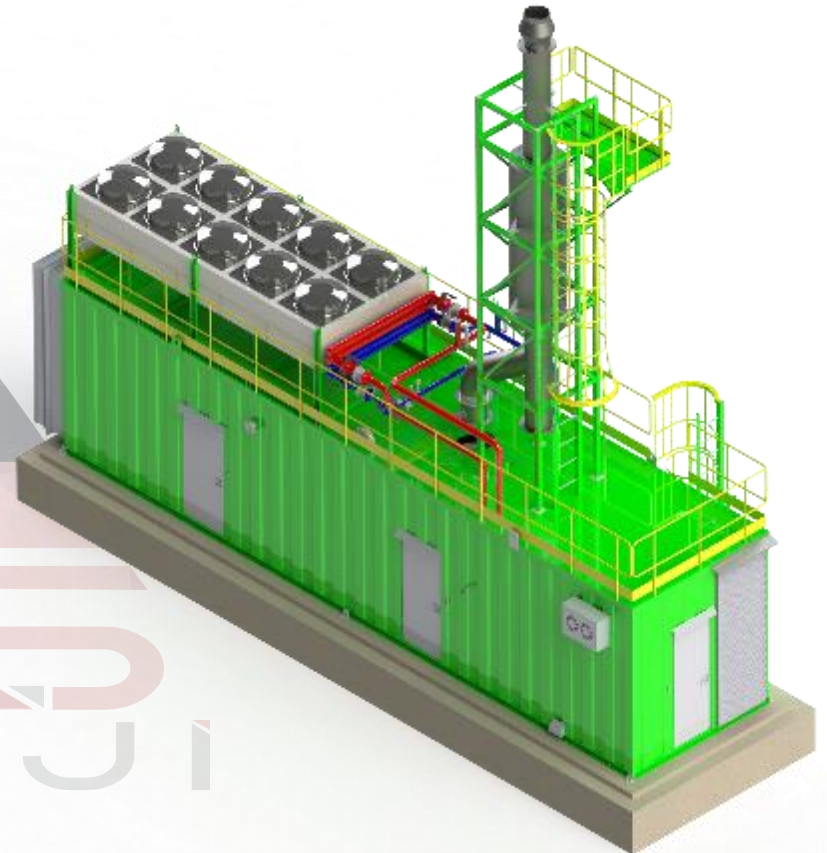





# ABOUT COMPANY - PRODUCTS

CHP UNIT





# ABOUT COMPANY - PRODUCTS

CHP AUXILIARY UNITS

JETCAP

SILENCER

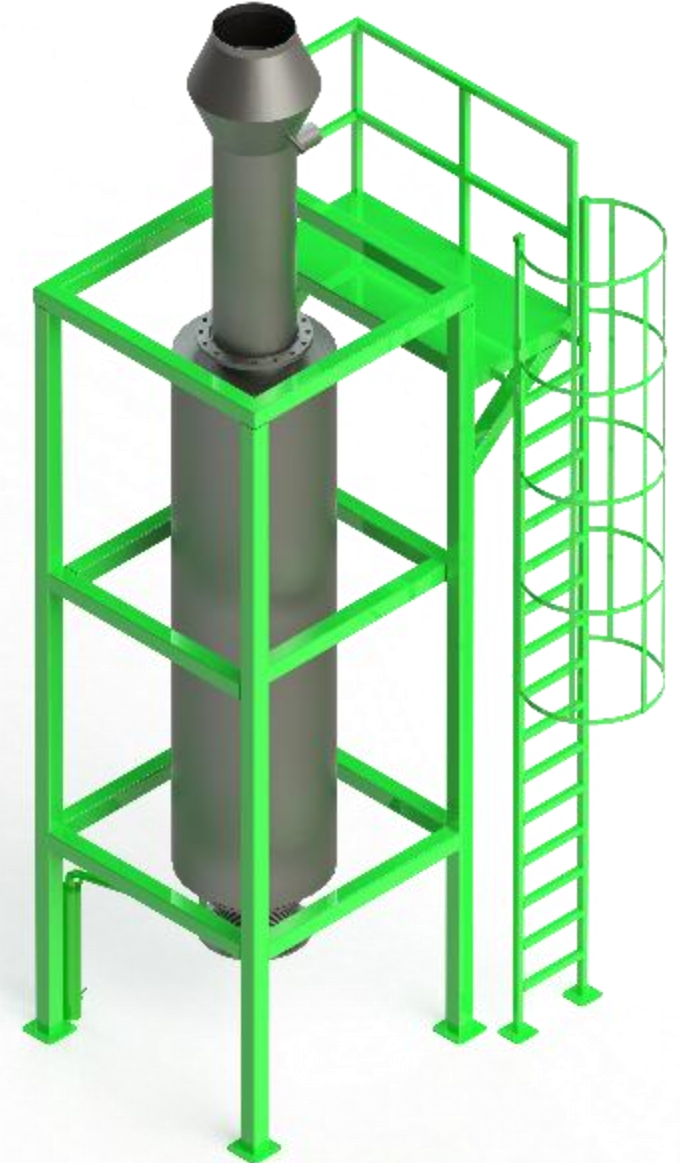
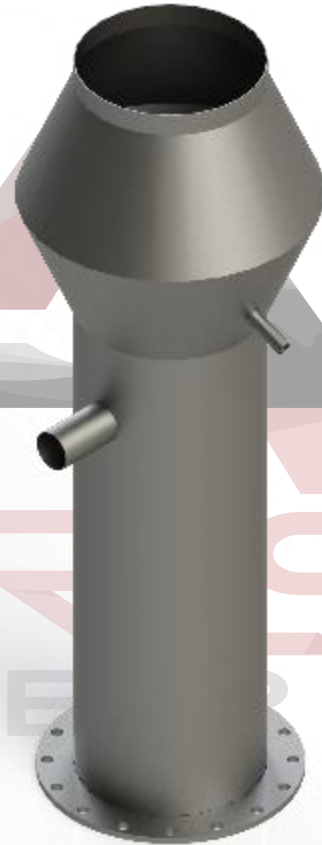





# ABOUT COMPANY - PRODUCTS

## CHP AUXILIARY UNITS







# ABOUT COMPANY - PRODUCTS

PADDLE DIGESTATE DRYER

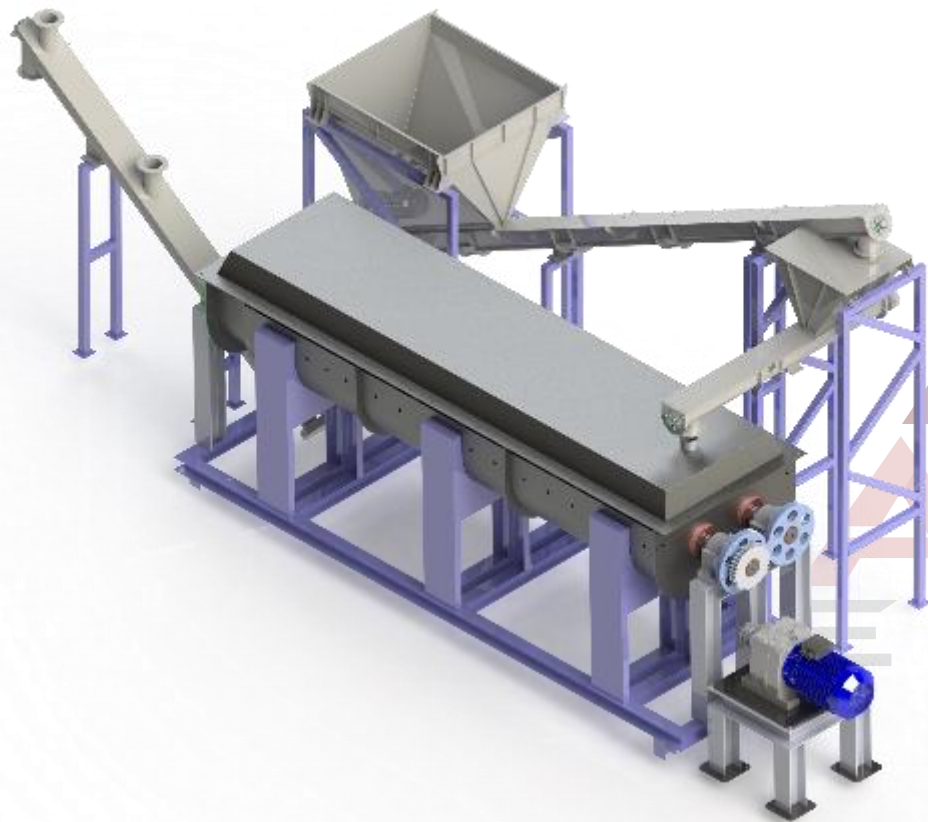

PLUG FLOW MINI DIGESTER

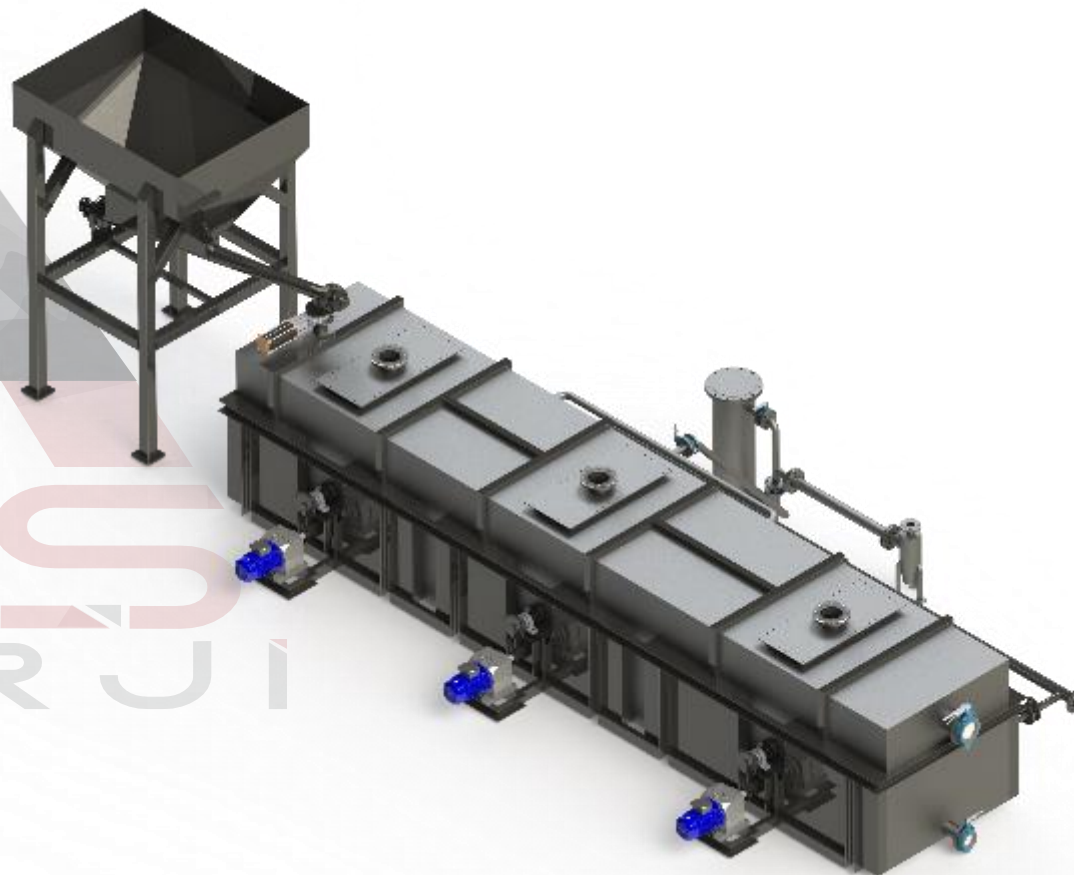



# ABOUT COMPANY - PRODUCTS

PADDLE DIGESTATE DRYER



PLUG FLOW MINI DIGESTER







# ABOUT COMPANY - PRODUCTS

## BIOGAS UPGRADING SYSTEM - HIGH PRESSURE WATER SCRUBBER



ARIS  
ENERJI

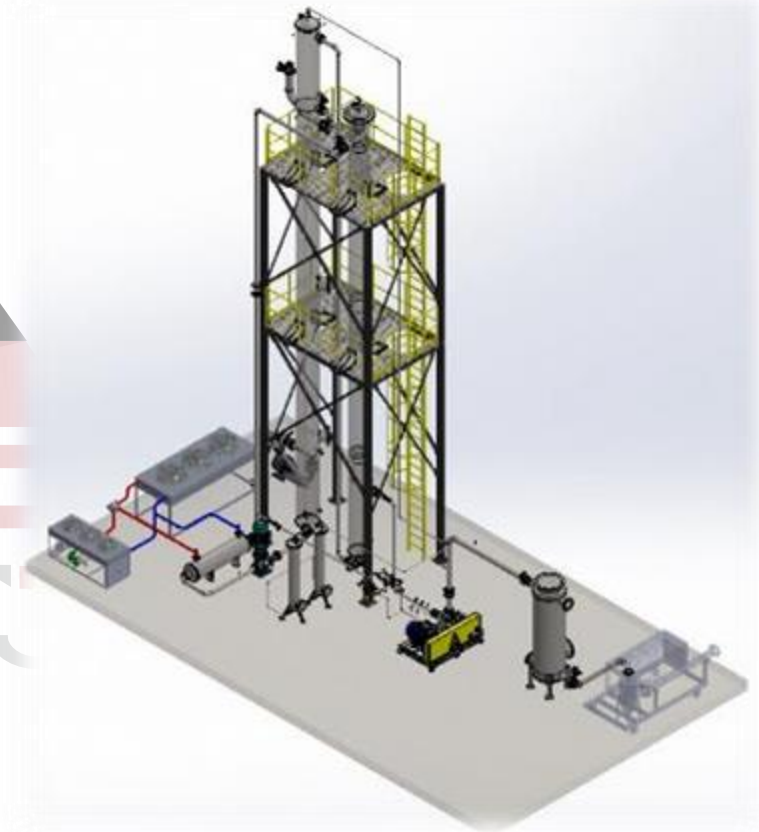





# ABOUT COMPANY - PRODUCTS

## BIOGAS UPGRADING SYSTEM - HIGH PRESSURE WATER SCRUBBER

Design and manufacturing is done.

We just agreed with one of our customer to install & validate this system for his LFG site. Equipment are sent to site for installation.





# ABOUT COMPANY - PRODUCTS

BIOGAS UPGRADING SYSTEM

ALTERNATIVE SYSTEMS – ONGOING

As an alternative option; our study is going on in design phase for;

- Membrane System
- PSA System

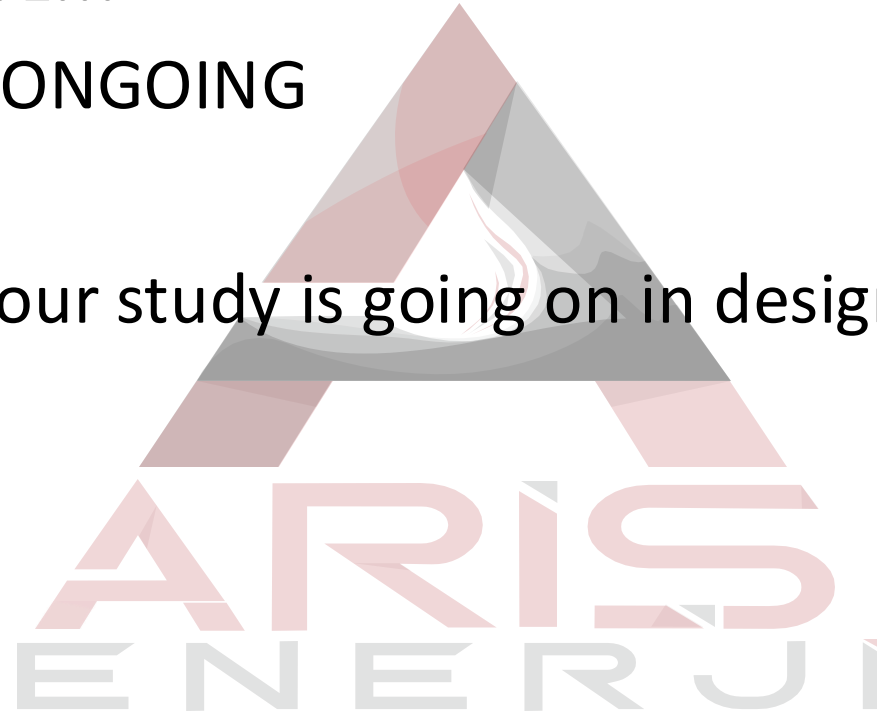



# ABOUT COMPANY - PRODUCTS

## AUTOMATION – SOFTWARE

Our automation team are enable to develop control software in accordance with system requirements and customer needs...

We generally use Siemens, Schneider PLC and HMI.







# ABOUT COMPANY - PRODUCTS

## AUTOMATION - SOFTWARE

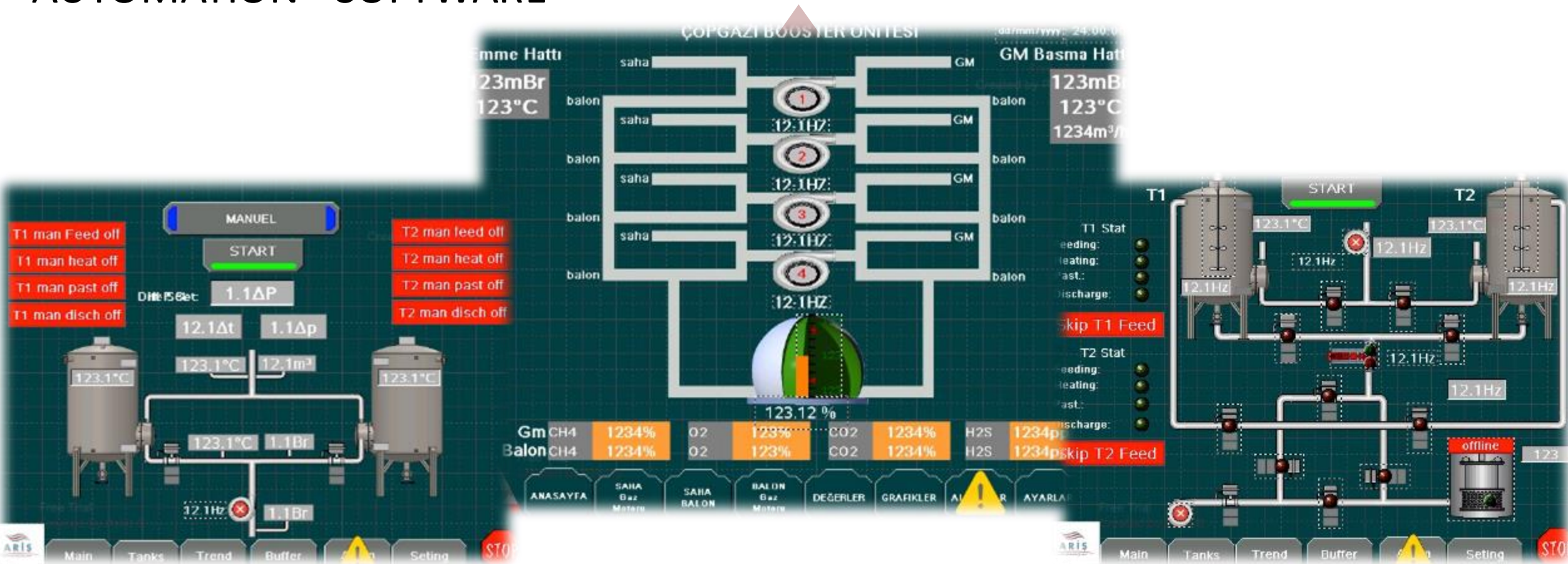



# ABOUT COMPANY - PRODUCTS

AUTOMATION – CABLING –  
PANEL PRODUCTION







# ABOUT COMPANY - PRODUCTS

PIPING – STAINLESS STEEL







# ABOUT COMPANY - REFERENCES

In Turkey there are 156 Biogas/LFG Power Plants (2022).

In 99 of them our products are used.

6 of LFG Power Plants were operated for a limited duration by us.





# ABOUT COMPANY - REFERENCES

## Overseas References

- Greece
- Finland
- Colombia
- Mongolia
- Somalia

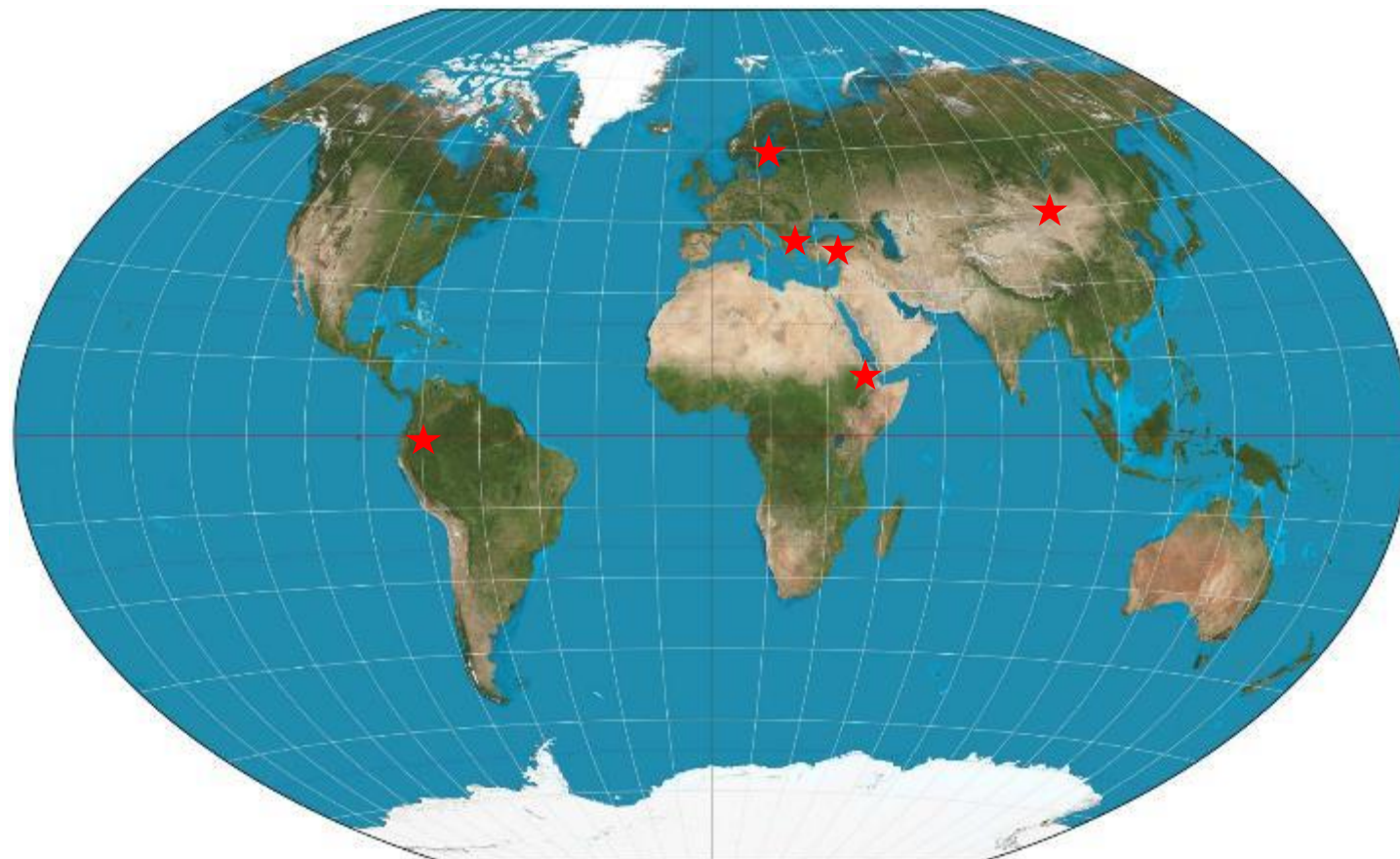



ARİŞ ENERJİ ANONİM ŞİRKETİ

[www.arisenerji.com.tr](http://www.arisenerji.com.tr)

+905323100960

ARIS  
ENERJİ